



ETHERNET EXTENSION EXPERTS

Enable-IT 820P Extended Ethernet Quickstart Guide



INSTALLING THE 820P EXTENDED ETHERNET KIT

The Enable-IT 820P Extended Ethernet Kit has a distance restriction of 900ft or 275m over Category 2 up to Category 6 wiring from device extension to device extension. Therefore quick, simple site surveys and installation planning are highly recommended.

This chapter describes the recommended installation process for the Enable-IT 820 Pro Extended Ethernet Kit. It covers the following topics:

- Site Plan – Installation Design Considerations
- Unpacking the Enable-IT 820P Extended Ethernet Kit
- Performing the On-Site Installation

Site Plan - Installation Design Considerations

- Total distance of 900ft / 275m wiring from 820P to remote LAN device.
- 4 Pair Telco wiring or greater for the Enable-IT 820P Extended Ethernet Unit.
- Wire pair used must be straight through, no taps/connection points.
- Twisted Pair cabling delivers the best performance over distance.
- Cisco PoE compatible and single line injector/midspan support built in.
- Transparent to single line 802.3af PoE or 802.3at PoE Plus devices.

Option 1 – Single line LAN Extension up to 900ft / 275m

We highly recommend a quick test to ensure the working order of your 820P unit. To do this, please power on the 820P unit using the 5v power adapter. Then connect your originating LAN device to the 820P LAN IN port. Next, attach a LAN device to the Interlink Out port on the 820P unit. Then power on your remote LAN device locally. The 820P unit should now be powered up and passing LAN data.

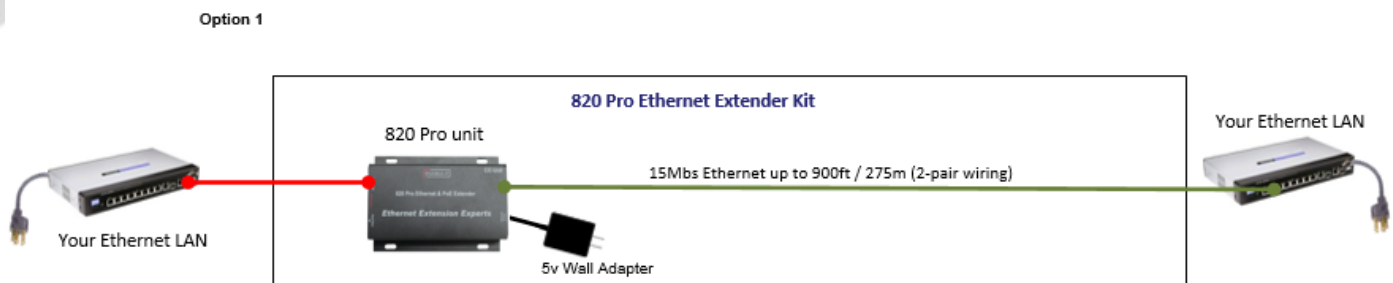

Network Configuration

In some instances, your Ethernet switch, desktop computer, laptop, WiFi Access Point, or any LAN device not mentioned may need to be configured for 10Mbps auto-sensing as the 820 Pro is a 10Mbps Ethernet switch. It may be the case that your Ethernet switch is not passing data through the 820 Pro to your remote LAN device, therefore setting the LAN configuration on your device to 10Mbps will allow it to recognize the 820 Pro switch settings.

Option 2 & 3 – Single line PoE pass-through / LAN Extension to your remote PoE device up to 900ft / 275m using your own 4 Pair 802.3af / 802.3at PoE Injector / Midspan

The 820 Pro can also be used to extend PoE pass-through to power on a remote PoE device using your own 4 Pair 802.3af or 802.3at Compliant PoE injector or midspan up to 900ft or 275m. Please do the following to ensure proper installation of your equipment:

To do this, please power on your 4 Pair, 802.3af / 802.3at PoE Injector/Midspan. Attach a patch cord from your LAN source to the PoE/Data IN port on the injector. Then run another patch cord from the PoE/Data OUT port to the LAN & PoE IN port on the 820 Pro unit. Next, attach a PoE LAN device to the Interlink Out port on the 820 Pro unit. The 820 Pro unit as well as your remote PoE device should now be powered up and running.

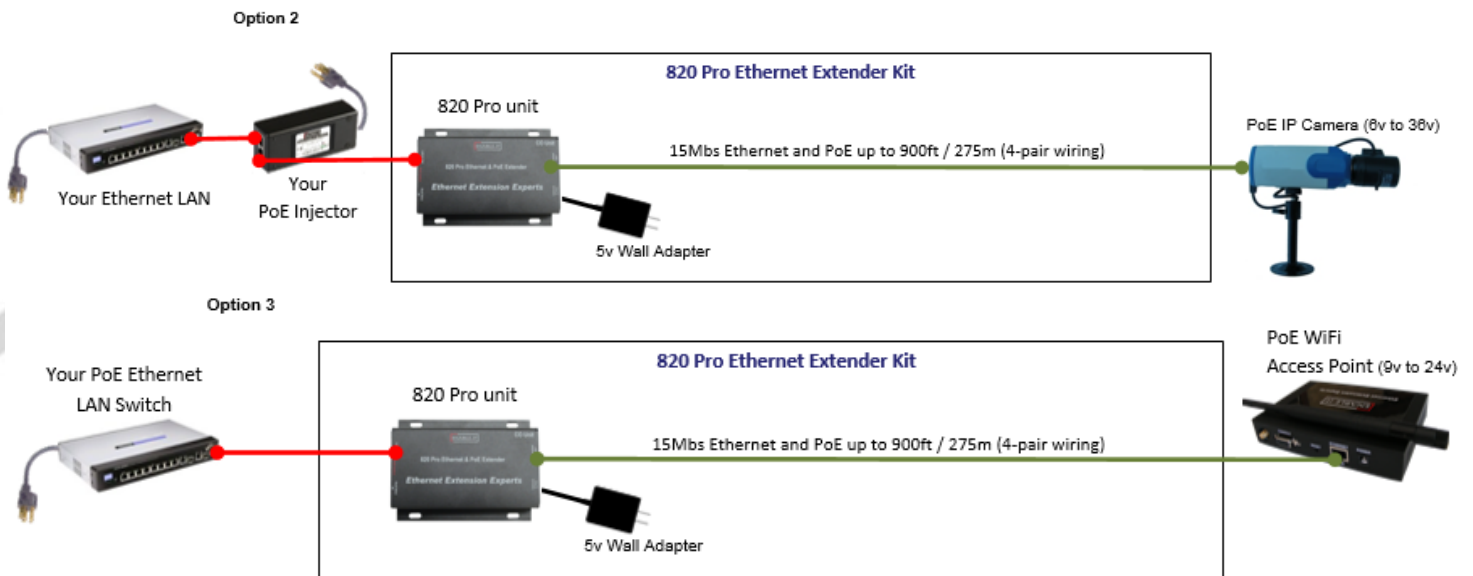

LED indicators will provide visual operational status of the 820 Pro unit.

820 LAN & PoE IN – Slow yellow LED flashing indicates LAN connectivity. Flickering yellow LED indicates LAN traffic.

820 Interlink Out 5v Power – Solid green LED indicates that the 820 is powered on and running

DIP Switch Settings: DIP switches 1 – 4:
Down (ON) - Enable PoE pass-through
UP (OFF) – Disable PoE pass-through

Default DIP Settings: DIP switches 1 – 4:
UP (OFF) PoE Disabled for Data only use

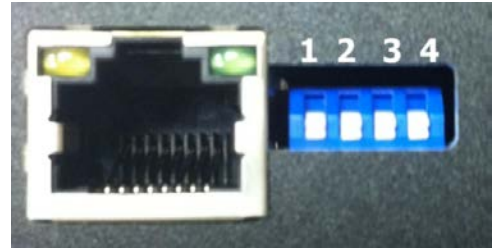

For installation at your desired location, keep in mind the following:
The backbone cable between the CO and your end device – RJ-45 Interlink port uses all 4-pairs of wire. (1,2,3 & 6 for data and 4,5,7 and 8 for PoE).

DO NOT INSERT ANY BLANK RJ-45 HEADS INTO ANY PORTS BEFORE CRIMPING – OTHERWISE YOU WILL RENDER THE PORT USELESS – BENT PINS

Attach RJ-45 Male heads to your existing wiring and follow the diagram below. For data only use pins 1, 2, 3 & 6. For Data and PoE use all pins. PoE uses pins 4, 5, 7 & 8

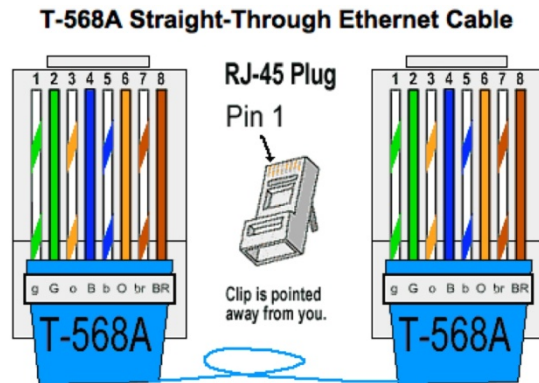

Unpacking the Enable-IT 820 Pro Extended Ethernet Kit

Carefully remove the Enable-IT 820 Pro Extended Ethernet Unit and all packing materials from the box. Verify that the items listed below are present. Make sure that the equipment supplied matches what you ordered. If any items are missing or damaged, please contact your Enable-IT or your distributor for assistance.

- (1) Enable-IT 820 Pro Extended Ethernet Unit
- (1) 5v Wall power
- (1) LAN Ethernet Patch Cord for end device attachment
- (1) Enable-IT Quickstart Guide (This document)

TECHNICAL SUPPORT

Enable-IT, Inc.'s Customer Care Team support is available directly to customers and distributors. All support requests are processed through the online support portal. This allows us to provide assigned support ticket numbers in order to bring closure to any technical issues.

Online Technical Services

The Enable-IT Support Portal is available 24/7 to open a ticket or check the status of one. Please use this support website as your first source for help as it contains an on-line knowledge base of articles, documentation, FAQ's and other problem-solving resources. This web-based support resource provides the quickest solution to the most common technical support issues.

Returning Products for Warranty Repair

Enable-IT, Inc. warrants to the original purchaser of the Product ("you" or the "End User") that, for the four (4) year period commencing on the date the Product was purchased (the "Warranty Period"), the Product will be substantially free from defects in materials and workmanship under normal use and conditions. **Electrical damage is not an item that is covered under this warranty, extended warranties or Advanced Replacement Program (AREP).**

In order to obtain an authorized RMA approval, the End User must complete the required information online located at . If you have questions or difficulty completing this information you may contact the Customer Care Team at 888-309-0910 between the hours of 8:00 a. m. and 5:00 p.m. PT.

Please ship Authorized RMAs to:

Enable-IT Processing Facility
16600 Harbor Blvd, Suite I
Fountain Valley, CA 92708-1363

Returning Products for Refund

Enable-IT, Inc. offers a generous 45-Day refund on a single Ethernet Extender Kit only, and is subject to a 15% Restocking Fee. Shipments without a valid or authorized RMA number, or sent to our corporate Las Vegas address, can be refused and / or billed for additional shipping.